

PANEL METER P1224L

- current input 4÷20 mA
- accuracy class: 0.1
- measurement resolution <math><1\mu\text{A}</math>
- supplied from input current loop
- fully programmable

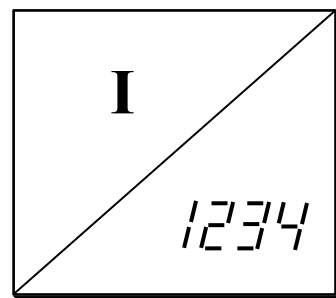

Panel meter P1224L is best suited to display physical quantities transmitted over the standard 4÷20mA signal. To this end both linear and non-linear transfer characteristics may be defined – the latter with a table prepared under any text editor or approximated with power series. Independently, an option of regulating input signal's zero and gain within $\pm 2\%$ may be employed. The meter is supplied from input signal and does not require any additional supply. This leads to increased voltage drop on input terminals that, however, does not exceed 3.8V at 20mA input current.

Any transfer characteristic is defined over the range of 4÷20mA. For input signals outside of this range but still within extended range of 3.75÷21.75mA the meter displays value approximately corresponding to the signal - at the same time indicating the fact by blinking the display. Outside the extended range, symbols indicating over-range, '—', or under-range, '—', are displayed. When used to indicate directly the measured current, the meter displays valid values over range extended to ca. 1.5÷22mA.

User-friendly configuration software runs under Microsoft Windows® and is freely available on our web page, www.cciba.eu. All that is needed is a low-cost adapter connected between PC's RS232 serial port or USB port and programming port of the meter. Separate power supply or connection to current source is not required for configuration. T1201 or T1205 (T1206 if galvanic isolation is required) adapter should be applied for, respectively, RS232 or USB port.

Programming port of the meter may be also used for controlling external 4÷20mA output, like the T1220 module. Output of the T1220 module is galvanically separated from the meter and reflects the displayed values normalized to 4÷20mA signal, i.e. the meter input current modified by any transfer characteristic employed within the meter.

The block scheme of P1224L is shown below. Signal connected to input terminals, after passing protective circuitry is low-pass filtered, amplified and converted to digital value. Processor performs the necessary calculations and sends the result to 4-digit, 20mm high LED display. Displayed values may range from -1999 to 9999 with appropriately placed digital dot.

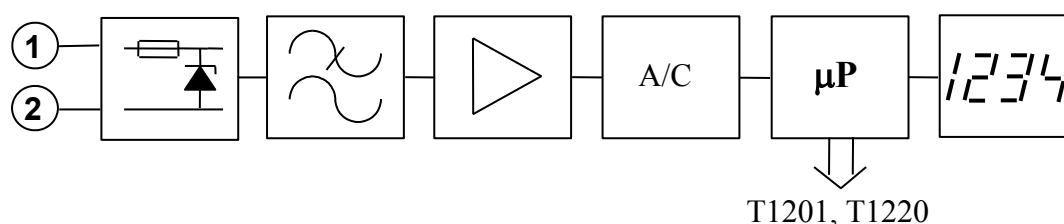

The input signal undergoes a complex filtration. There are several filters applied which remove various noise components. First, the signal passes a low-pass filter eliminating high-frequency noise. Very effective power-net frequency digital filter is applied next. The processor follows the residual noise left and removes any momentary signal jumps. Final filtration, being actually a 'smart' averaging that allows quick adaptation to faster signal changes while preserving long integration time constant for slowly changing signal, takes place after initial calculations and is described by two parameters accessible for the user: integration time constant, and filtration range. The later is expressed as percentage of the input range and serves to determine the level of signal change between consecutive measurements above which a new average is started. It may sound complicated but is easy in application, especially so, that the PC code may estimate both parameters by itself. The user may correct them at a later time, having some experience about the object's producing input signal behaviour. There is also a 'spurious signal' filter present that removes from signal any non-symmetric spikes of large amplitude, which would otherwise distort the result even if long averaging times were used, and the user may switch it on defining the level above which it should start working. This parameter is also expressed as percentage of the input range and should not be lower than 10 times the filtration range parameter.

The measured value is being corrected according to calibration constants and thus giving the input current level. If a transfer characteristic was defined, respective calculations modify the result. In case of table-defined characteristic the meter uses internally a 200 segments approximation keeping the estimated value's error at minimum. User-defined zero and gain corrections are then applied and the resulting value is displayed.

Example of connecting the meter as shown below.

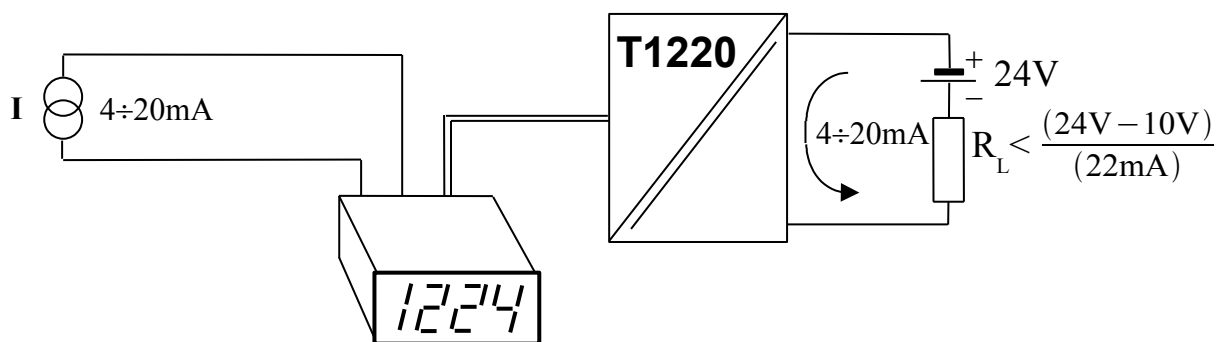

The configuration program does not need any special installation. After starting the program a serial port number (COMx) should be chosen before a communication with the meter may be started. This may be done by clicking on the icon with picture of a computer. As a default, COM1 is used, but the program saves basic settings and last used port will be remembered and used next time the program is run.

Program starts communication whenever a meter is connected (through one of adapters). For standard operations it is enough to use only the icons placed in the toolbar. A hint appears whenever the cursor rests on an icon for more than half a second. The same applies to all fields and buttons, which may be used at the moment.

It is a good practice to read the settings from the connected meter first, before any changes are applied. An icon with open book serves to this purpose. Clicking on the icon with a pen and a piece of paper will cause downloading of configuration settings to the meter (provided that the configuration is complete). Preparation of configuration file is also possible without any meter connected.

Naturally, the user may save in a file or print the settings of any meter for future reference.

To correct the zero and gain, or simulate these changes, one has to know a password. The initial password is 'ciba' and may be changed from menu (Options/General) to any other combination of letters and numbers.

As mentioned before, for non-linear transfer characteristics, a user-defined text table may be used. The configuration program applies elaborate mathematical methods to approximate the supplied characteristics, which allows to limit the user input to as few points as necessary and still obtain smooth curves.

Technical data

Input:	current:	4÷20 mA (1.5÷22mA) voltage drop 3.8V (20mA) dynamic internal resistance < 20 Ω
---------------	----------	--

Accuracy class:	0.1
------------------------	-----

Other technical parameters:

single measurement duration	80 ms
maximum nonlinearity	0.02 %
measurement resolution	<1 μA
temperature coefficient	100ppm/°C
warm-up time	5 min
operating temperature range	-20÷50 °C
storage temperature range	-40÷80 °C
relative humidity	30÷75 %
ambient pressure	1000±200 hPa
external magnetic field	0÷400 A/m
working position	irrelevant
external dimensions	48×96×120mm
panel cut-out dimensions	44×91.5mm
housing protection type	IP 20

Absolute maximum ratings:

input voltage	36 V
input current (internally limited)	100 mA



CCIBA sp.j.

54-616 Wrocław, Poland, ul. Tarnopolska 10

tel/fax (+48) 71 7954080

www.cciba.eu